



SY88303BL

3.3V, 3.2Gbps CML Limiting Post Amplifier with Wide Loss-of-Signal Detection Range

General Description

The SY88303BL low-power limiting post amplifiers are designed for use in fiber-optic receivers. These devices connect to typical transimpedance amplifiers (TIAs). The linear signal output from TIAs can contain significant amounts of noise and may vary in amplitude over time. The SY88303BL quantizes these signals and output CML-level waveforms.

The SY88303BL operates from a single +3.3V power supply, over temperatures ranging from -40°C to $+85^{\circ}\text{C}$. With their wide bandwidth and high gain, signals with data rates up to 3.2Gbps, and as small as 10mV_{PP} , can be amplified to drive devices with CML/PECL inputs.

The device generates a loss-of-signal (LOS) open-collector TTL output. The LOS function is optimized to detect a wide input range, as shown in the typical operating characteristic curve on Page 6. A programmable loss-of-signal level-set pin (LOS_{LVL}) sets the sensitivity of the input amplitude detection.

LOS asserts high if the input amplitude falls below the threshold sets by LOS_{LVL} and de-asserts low otherwise. The enable bar input (/EN) de-asserts the true output signal without removing the input signal. The LOS output can be fed back to the /EN input to maintain output stability under a loss-of-signal condition. Typically, 3.5dB LOS hysteresis is provided to prevent chattering.

Datasheet and support documentation can be found on Micrel's web site at: www.micrel.com.

Features

- Loss-of-signal detection circuit optimized to detect a wide input range
- Chatter-free Open-Collector TTL Loss-of-Signal (LOS) output
- Single 3.3V power supply
- 155Mbps to 3.2Gbps operation
- Low-noise CML data outputs
- Programmable LOS level set (LOS_{LVL})
- Available in a tiny 10-pin EPAD-MSOP and 16-pin MLF[®] package

Applications

- PON
- Gigabit Ethernet
- 1X and 2X Fibre Channel
- SONET/SDH: OC 3/12/24/48 – STM 1/4/8/16
- High-gain line driver and line receiver

Markets

- FTTX
- Optical transceivers
- Datacom/Telecom
- Low-gain TIA interface
- Long-reach FOM

Typical Application

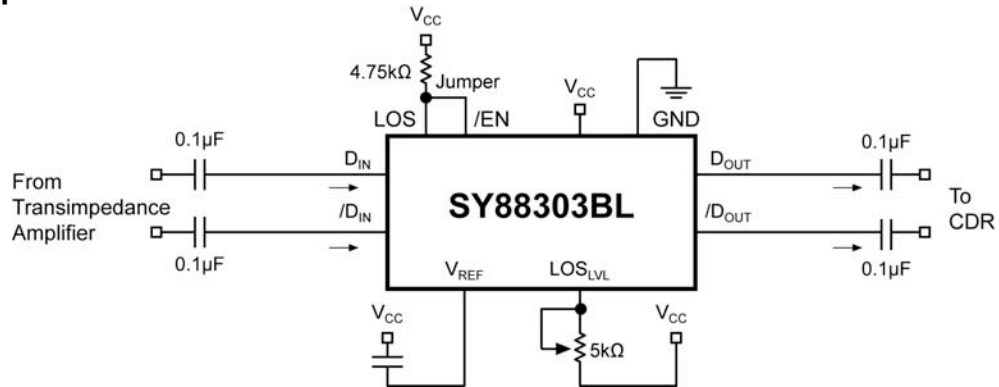

Pin Configuration

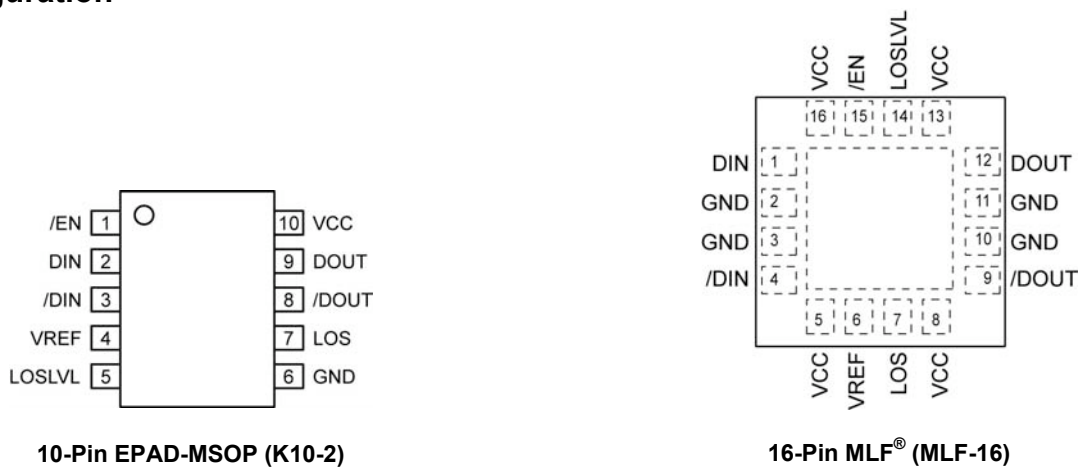

Ordering Information

Part Number	Package Type	Operating Range	Package Marking	Lead Finish
SY88303BLEY	K10-2	Industrial	303B with Pb-Free bar line indicator	Matte-Sn Pb-free
SY88303BLEYTR ⁽¹⁾	K10-2	Industrial	303B with Pb-Free bar line indicator	Matte-Sn Pb-free
SY88303BLMG	MLF-16	Industrial	303B with Pb-Free bar line indicator	NiPdAu Pb-free
SY88303BLMGTR ⁽¹⁾	MLF-16	Industrial	303B with Pb-Free bar line indicator	NiPdAu Pb-free

Note:

- 1. Tape and Reel.

Pin Description

Pin Number (MSOP)	Pin Number (MLF [®])	Pin Name	Type	Pin Function
1	15	/EN	TTL Input: Default is low.	Enable bar: De-asserts true data output when High.
2	1	DIN	Data Input	True data input with 50Ω termination to V _{REF} .
3	4	/DIN	Data Input	Complementary data input w50Ω termination to V _{REF} .
4	6	VREF		Reference Voltage: Placing a capacitor here to V _{CC} helps stabilize.
5	14	LOSLVL	Input	Loss-of-Signal Level Set: A resistor from this pin to V _{CC} sets the threshold for the data input amplitude at which the LOS output will be asserted.
6 Exposed Pad	2, 3, 10, 11 Exposed Pad	GND	Ground	Device ground. Exposed pad must be connected to PCB ground plane.
7	7	LOS	Open Collector TTL Output	Loss-of-Signal: Asserts high when the data input amplitude falls below the threshold sets by LOS _{LVL} . For proper operation, install an external 4.75kΩ pull-up resistor at this output.
8	9	/DOUT	CML Output	Complementary data output.
9	12	DOUT	CML Output	True data output.
10	5, 8, 13, 16	VCC	Power Supply	Positive power supply.

Absolute Maximum Ratings⁽¹⁾

Supply Voltage (V_{CC}) 0V to +4.0V
 Input Voltage (DIN, DIN) 0 to V_{CC}
 Output Current (I_{OUT})
 Continuous ± 50 mA
 Surge ± 100 mA
 /EN Voltage 0 to V_{CC}
 V_{REF} Current $-800\mu A$ to $+500\mu A$
 LOS_{LVL} Voltage V_{REF} to V_{CC}
 Lead Temperature (soldering, 20sec.) $260^{\circ}C$
 Storage Temperature (T_s) $-65^{\circ}C$ to $+150^{\circ}C$

Operating Ratings⁽²⁾

Supply Voltage (V_{CC}) +3.0V to +3.6V
 Ambient Temperature (T_A) $-40^{\circ}C$ to $+85^{\circ}C$
 Junction Temperature (T_J) $-40^{\circ}C$ to $+125^{\circ}C$
 Junction Thermal Resistance⁽³⁾
 EPAD-MSOP
 θ_{JA} (Still-Air) $38^{\circ}C/W$
 ψ_{JB} $22^{\circ}C/W$
 MLF[®]
 θ_{JA} (Still-Air) $61^{\circ}C/W$
 ψ_{JB} $38^{\circ}C/W$

DC Electrical Characteristics

$V_{CC} = 3.0V$ to $3.6V$; $R_L = 50\Omega$ to V_{CC} ; $T_A = -40^{\circ}C$ to $+85^{\circ}C$; typical values at $V_{CC} = 3.3V$, $T_A = 25^{\circ}C$.

Symbol	Parameter	Condition	Min	Typ	Max	Units
I_{CC}	Power Supply Current	No output load		38	60	mA
V_{LOSLVL}	LOS_{LVL} Voltage		V_{REF}		V_{CC}	V
V_{OH}	CML Output HIGH Voltage		$V_{CC}-0.020$	$V_{CC}-0.005$	V_{CC}	V
V_{OL}	CML Output LOW Voltage		$V_{CC}-0.475$	$V_{CC}-0.4$	$V_{CC}-0.350$	V
V_{OFFSET}	Differential Output Offset				± 80	mV
V_{REF}	Reference Voltage		$V_{CC}-1.48$	$V_{CC}-1.32$	$V_{CC}-1.16$	V
Z_i	Single-Ended Input Impedance		40	50	60	Ω

TTL DC Electrical Characteristics

$V_{CC} = 3.0V$ to $3.6V$; $T_A = -40^{\circ}C$ to $+85^{\circ}C$.

Symbol	Parameter	Condition	Min	Typ	Max	Units
V_{IH}	/EN Input HIGH Voltage		2.0			V
V_{IL}	/EN Input LOW Voltage				0.8	V
I_{IH}	/EN Input HIGH Current	$V_{IN} = 2.7V$ $V_{IN} = V_{CC}$			20 100	μA μA
I_{IL}	/EN Input LOW Current	$V_{IN} = 0.5V$	-300			μA
I_{OH}	LOS Output Leakage	$V_{OH} = 3.6V$			100	μA
V_{OL}	LOS Output LOW Level	$I_{OL} = +4mA$			0.5	V

Notes:

1. Permanent device damage may occur if absolute maximum ratings are exceeded. This is a stress rating only and functional operation is not implied at conditions other than those detailed in the operational sections of this data sheet. Exposure to absolute maximum rating conditions for extended periods may affect device reliability.
2. The data sheet limits are not guaranteed if the device is operated beyond the operating ratings.
3. Thermal performance assumes the use of a 4-layer PCB. Exposed pad must be soldered (or equivalent) to the device's most negative potential on the PCB.

AC Electrical Characteristics

$V_{CC} = 3.0V$ to $3.6V$; $R_L = 50\Omega$ to V_{CC} ; $T_A = -40^\circ C$ to $+85^\circ C$; typical values at $V_{CC} = 3.3V$, $T_A = +25^\circ C$.

Symbol	Parameter	Condition	Min	Typ	Max	Units
t_r, t_f	Output Rise/Fall Time (20% to 80%)	Note 4		60	120	ps
t_{JITTER}	Deterministic Random	Note 5 Note 6		15 5		ps _{PP} ps _{RMS}
V_{ID}	Differential Input Voltage Swing	Figure 1	10		1800	mV _{PP}
V_{OD}	Differential Output Voltage Swing	$V_{ID} \geq 12mV_{PP}$, Figure 1	700	800	950	mV _{PP}
T_{OFF}	LOS De-assert Time			2	10	μs
T_{ON}	LOS Assert Time			2	10	μs
LOS_{DL}	Low LOS De-assert Level	$R = 15k\Omega$, Note 8		27		mV _{PP}
LOS_{AL}	Low LOS Assert Level	$R = 15k\Omega$, Note 8		18		mV _{PP}
HYS_L	Low LOS Hysteresis	$R = 15k\Omega$, Note 7		3.4		dB
LOS_{DM}	Medium LOS De-assert Level	$R = 5k\Omega$, Note 8		53	80	mV _{PP}
LOS_{AM}	Medium LOS Assert Level	$R = 5k\Omega$, Note 8	21	36		mV _{PP}
HYS_M	LOS Hysteresis	$R = 5k\Omega$, Note 7	2	3.5	6	dB
LOS_{DH}	High LOS De-assert Level	$R = 100\Omega$, Note 8		137	200	mV _{PP}
LOS_{AH}	High LOS Assert Level	$R = 100\Omega$, Note 8	70	94		mV _{PP}
HYS_H	High LOS Hysteresis	$R = 100\Omega$, Note 7	2	3.5	6	dB
B_{-3dB}	3dB Bandwidth			2		GHz
$A_{V(Diff)}$	Differential Voltage Gain			39		dB
S_{21}	Single-ended Small-Signal Gain		26	33		dB

Notes:

- Amplifier in limiting mode. Input is a 200MHz, 100mV_{PP} square wave.
- Deterministic jitter measured using 3.2Gbps K28.5 pattern, $V_{ID} = 10mV_{PP}$.
- Random jitter measured using 3.2Gbps K28.7 pattern, $V_{ID} = 10mV_{PP}$.
- This specification defines electrical hysteresis as 20log (LOS De-assert/LOS Assert). The ratio between optical hysteresis and electrical hysteresis is found to vary between 1.5 and 2, depending upon the level of received optical power and ROSA characteristics. Based upon that ratio, the optical hysteresis corresponding to the electrical hysteresis range 2dB-6dB, shown in the AC characteristics table, will be 1dB-3dB Optical Hysteresis.
- See "Typical Operating Characteristics" for a graph showing how to choose a particular $R_{LOS_{LVL}}$ for a particular LOS assert and its associated de-assert amplitude.

Typical Operating Characteristics

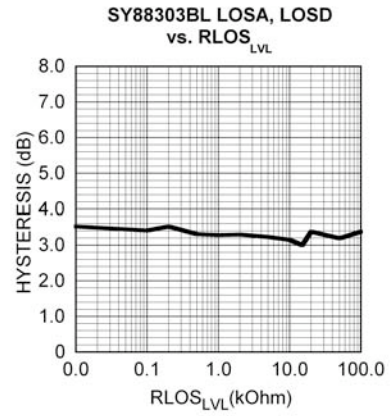
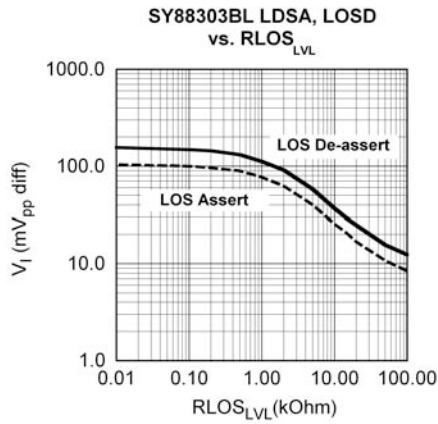

Functional Characteristics

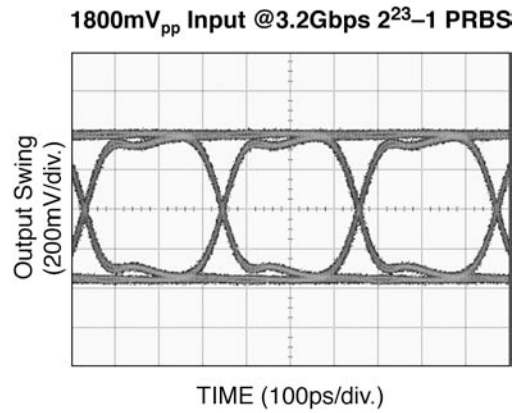
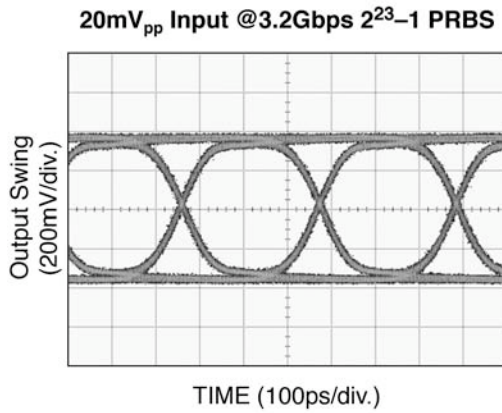

Functional Block Diagram

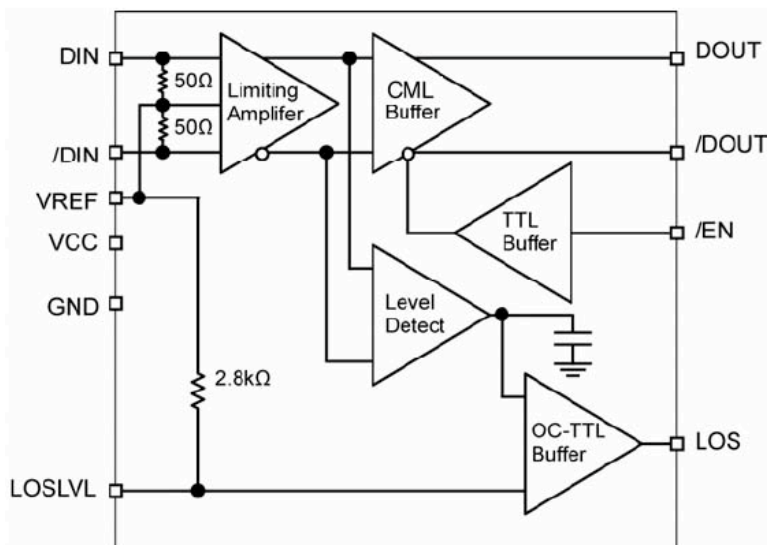

Detailed Description

The SY88303BL low-power limiting post amplifiers operate from a single +3.3V power supply, over temperatures from -40°C to $+85^{\circ}\text{C}$. Signals with data rates up to 3.2Gbps and as small as 10mV_{PP} can be amplified. Figure 1 shows the allowed input voltage swing. The SY88303BL generates a LOS output allowing feedback to /EN for output stability. LOS_{LVL} sets the sensitivity of the input amplitude detection.

Input Amplifier Buffer

Figure 2 shows a simplified schematic of the input stage. The high-sensitivity of the input amplifier allows signals as small as 10mV_{PP} to be amplified. The input amplifier also allows input signals as large as $1800\text{mV}_{\text{PP}}$. Input signals below 12mV_{PP} are linearly amplified with a typical 42dB differential voltage gain. Since it is a limiting amplifier, these devices output typically 800mV_{PP} voltage-limited waveforms for input signals greater than 12mV_{PP} . Applications requiring the SY88303BL to operate with strong signals should have the upstream TIA placed as close as possible to the devices' input pins. This ensures the best performance of the device.

Output Buffer

The SY88303BL CML output buffers are designed to drive 50Ω lines. The output buffer requires appropriate termination for proper operation. An external 50Ω resistor to V_{CC} for each output pin provides this. Figure 3 shows a simplified schematic of the output stage.

Loss-of-Signal

The SY88303BL generates a chatter-free LOS open-collector TTL output, as shown in Figure 4. LOS is used to determine that the input amplitude is large enough to be considered a valid input. LOS asserts high if the input amplitude falls below the threshold sets by LOS_{LVL} and de-asserts low otherwise. LOS can be fed back to the enable bar (/EN) input to maintain output stability under a loss-of-signal condition. /EN de-asserts the true output signal without removing the input signals.

Loss-of-Signal Level Set

Programmable LOS level-set pin (LOS_{LVL}) sets the threshold of the input amplitude detection. Connecting an external resistor between V_{CC} and LOS_{LVL} set the voltage at LOS_{LVL} . This voltage ranges from V_{CC} to V_{REF} . The external resistor creates a voltage divider between V_{CC} and V_{REF} , as shown in Figure 5.

Hysteresis

The SY88303BL typically provides 3.5dB LOS electrical hysteresis. By definition, a power ratio measured in dB is $10\log(\text{power ratio})$. Power is calculated as V_{IN}^2 / R for an electrical signal. Hence, the same ratio can be stated as $20\log(\text{voltage ratio})$. While in linear mode, the electrical voltage input changes linearly with the optical power and therefore, the ratios change linearly. Thus, the optical hysteresis in dB is half the electrical hysteresis in dB given in the data sheet. Since the SY88303BL is an electrical device, this data sheet refers to hysteresis in electrical terms. With 3.5dB LOS hysteresis, a voltage factor of 1.5 is required to assert or de-assert LOS.

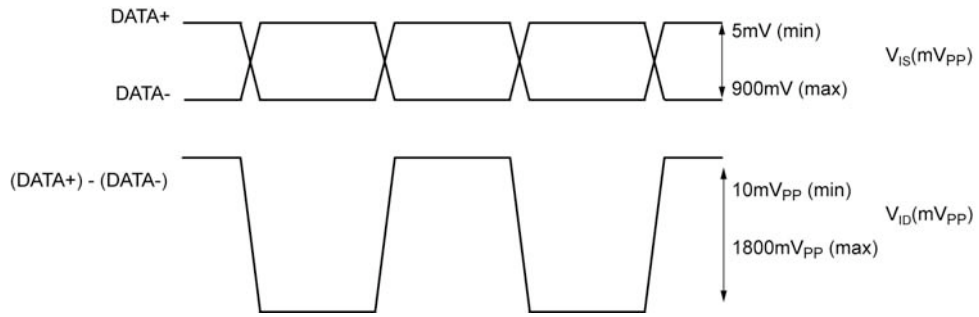

Figure 1. V_{IS} and V_{ID}

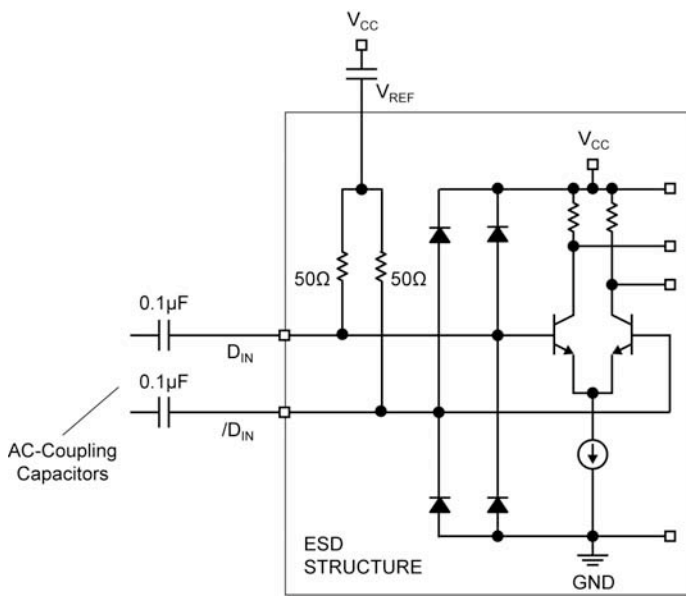

Figure 2. Input Structure

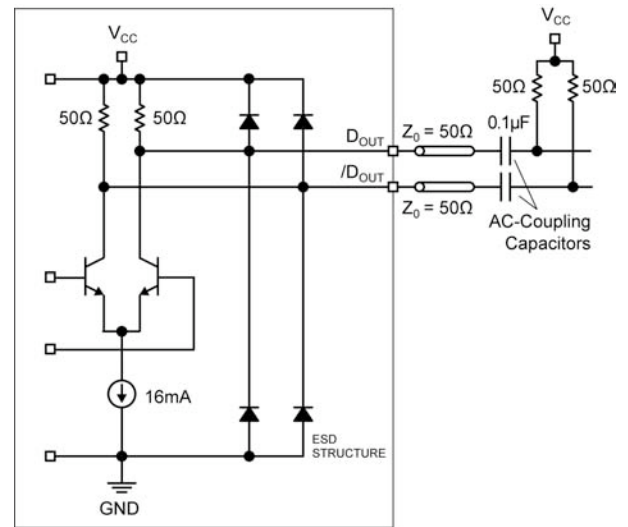

Figure 3. Output Structure

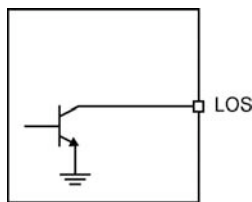

Figure 4. LOS Output Structure

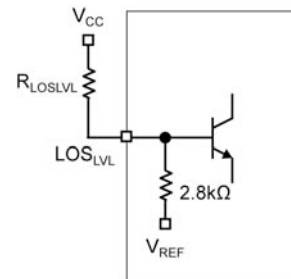
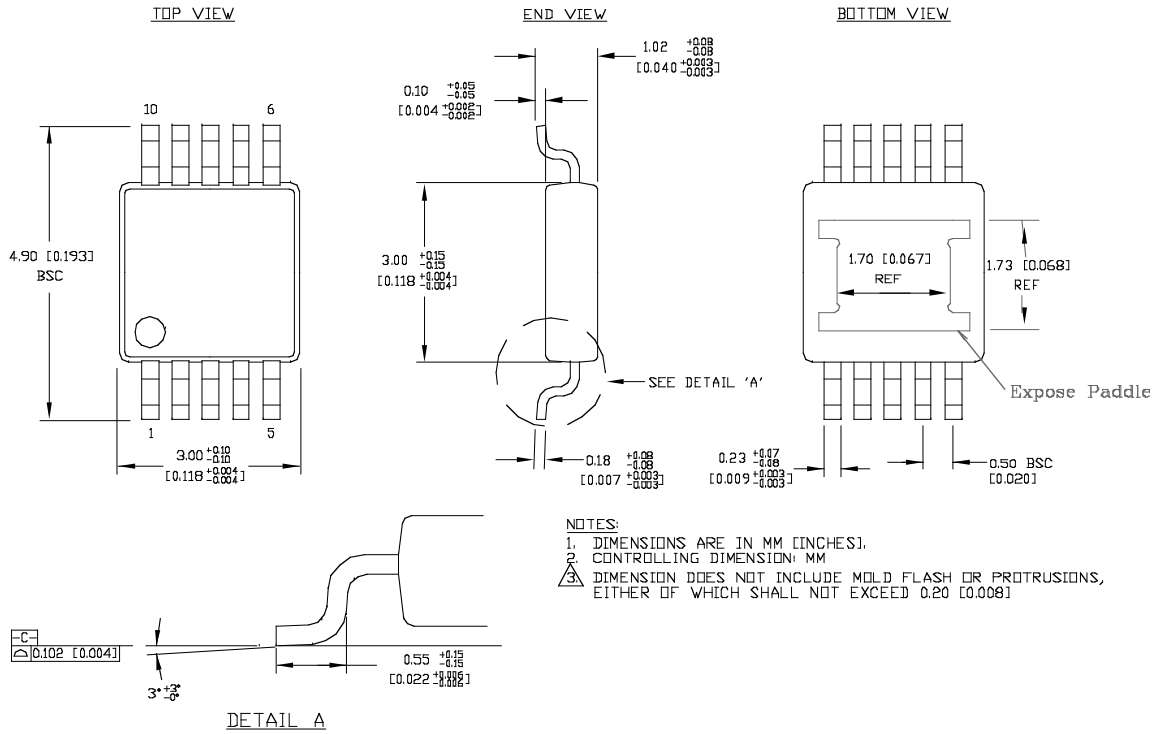
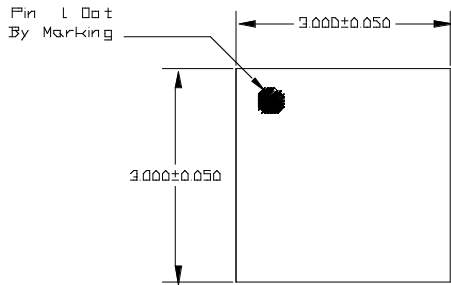

Figure 5. LOS_{LVL} Setting Circuit

Package Information



10-Pin EPAD-MSOP (K10-2)



TOP VIEW

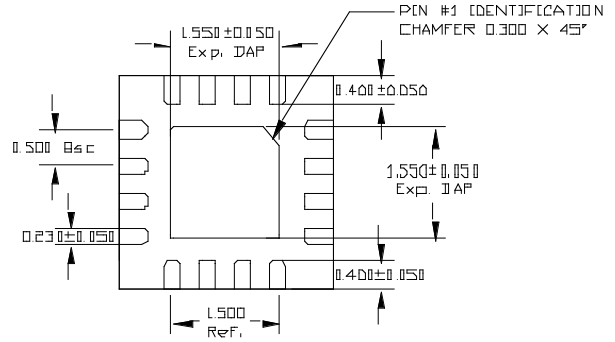

BOTTOM VIEW

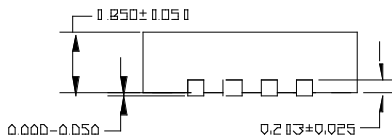

SIDE VIEW

- NOTE:
1. ALL DIMENSIONS ARE IN MILLIMETERS.
 2. MAX. PACKAGE WARPAGE IS 0.05 mm.
 3. MAXIMUM ALLOWABLE BURRS IS 0.076 mm IN ALL DIRECTIONS.
 4. PIN #1 DOT ON TOP WILL BE LASER/INK MARKED.

16-Pin MLF® (MLF-16)

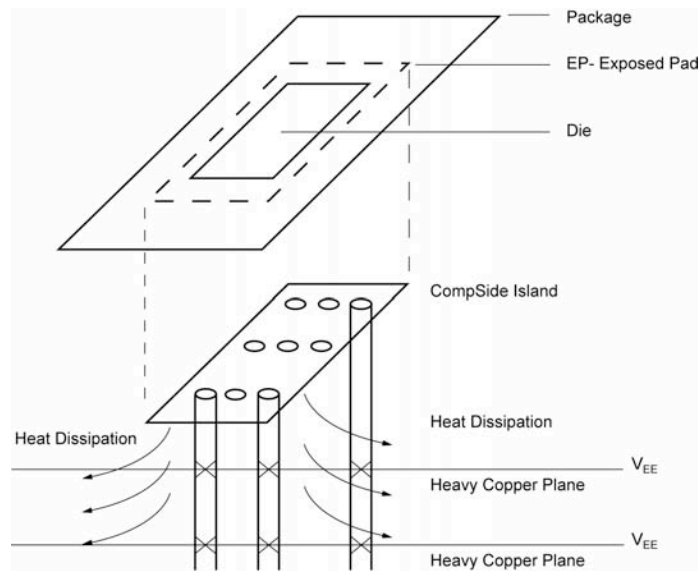

**PCB Thermal Consideration for 16-Pin MLF® Package
(Always solder, or equivalent, the exposed pad to the PCB)**

Package Notes:

1. Package meets Level 2 qualification.
2. All parts are dry-packaged before shipment.
3. Exposed pad must be soldered to a ground for proper thermal management, solder void has to be less than 50% of the epad area.

MICREL, INC. 2180 FORTUNE DRIVE SAN JOSE, CA 95131 USA
TEL +1 (408) 944-0800 FAX +1 (408) 474-1000 WEB <http://www.micrel.com>

The information furnished by Micrel in this data sheet is believed to be accurate and reliable. However, no responsibility is assumed by Micrel for its use. Micrel reserves the right to change circuitry and specifications at any time without notification to the customer.

Micrel Products are not designed or authorized for use as components in life support appliances, devices or systems where malfunction of a product can reasonably be expected to result in personal injury. Life support devices or systems are devices or systems that (a) are intended for surgical implant into the body or (b) support or sustain life, and whose failure to perform can be reasonably expected to result in a significant injury to the user. A Purchaser's use or sale of Micrel Products for use in life support appliances, devices or systems is a Purchaser's own risk and Purchaser agrees to fully indemnify Micrel for any damages resulting from such use or sale.

© 2007 Micrel, Incorporated.